

# *EnergyIN-WavEC Workshop Roadmap*

## *Energias Renováveis Offshore*

*DELIVERABLE 6* do  
'Estudo sobre as Energias Offshore em Portugal'  
do WavEC para o EnergyIN

Frank Neumann  
Alex Raventos  
Miguel Lopes  
Ana Brito e Melo

- Necessidades na fase actual de desenvolvimento
- Centros de Testes 10 nível Europeu
- Situação específica de Portugal
- Estudo de Mercado e Inquérito
- Avaliação dos custos dos centros de teste
- Modelo económico e resultados

# Ponto decisivo: dinamizar fase seguinte ou posição passiva?



- Para comprovar sobrevivência e funcionalidade no ambiente marítimo, experiência em escala real é o item mais crítico – não assuntos relacionados com PI ou testes em modelo;
- Competências “no mar” têm de ser identificadas – Centros de teste independentes irão dinamizar as capacidades regionais e a interacção com actores estrangeiros;
- Alguns investidores (empresas de energia) adoptaram uma abordagem “neutra” em relação a tecnologias/dispositivos, considerado como melhor maneira de avançar no mercado (Vattenfall, ESBI, ...) – objectivo é aprender sobre operação/manutenção e progresso genérico;
- Competências adquiridas em testes em escala real trazem credibilidade e beneficiam futuros projectos – na fase inicial, juntar/partilhar a experiência em assuntos não relevantes para a PI pode ser considerado vital;
- Entre maiores vantagens desta abordagem é a possibilidade de limitar custos;
- **Infraestruturas de teste operadas por uma entidade independente criada para beneficiar o sector pode aumentar significativamente as hipóteses de sucesso.**
- **Infraestruturas necessárias só serão possível com participação activa dos actores de mercado (inclusive proveitos por clientes potenciais para os locais)**

# Infra-estruturas de teste em Europa: um passo essencial



EMEC - European Maritime Energy Centre  
*Orkney, Scotland | 2003*

Runde  
*West-coast of Norway | 2009...*

Mayo Full-Scale Test Site  
*Ireland | 2008...*



Nissum Bredning Wave Energy Test Site  
*North western corner of Denmark | 2003*

Galway Bay 1:4 Test Site  
*Ireland | 2004*

Wave Hub  
*South West of Cornwall | 2007 / 2010*

SEMREV  
*Le Croisic/Bretagne | 2008...*

Bimep - Biscay Marine Energy Platform  
*Bilbao, Spain | 2008...*

-  Scale testing
-  Demonstration
-  Pre-commercial

Portuguese Pilot Zone  
*São Pedro de Moel | 2008...*

**Note: the Pilot Zone was not conceived for testing but for (pre-)commercial implementation phase!**

# Motivos para uma infra-estrutura de testes Portuguesa



## Criação de um cluster nacional associado à energia das ondas

- Não existem capacidades *offshore* do sector oil&gas que poderiam ser transmitidos
- Indústrias adjacentes (estaleiros, navegação, mergulho comercial, automação, serviços marítimos, etc) existem mas (ainda) não estão preparados para sector
- Operação e manutenção será o factor de competição mais vital na presente fase inicial do sector, e Portugal tem uma boa oportunidade de se posicionar.
- Algum conhecimento não relevante para PI (*MET-Ocean*; O&M genérico; segurança; legal; políticas; percepção pública/promoção,...) podia-se juntar e beneficiar sector

## Atrair desenvolvimento industrial e demonstração para Portugal

- Não existe nenhuma PI significativa 'residente' (ainda), mas potenciais fornecedores, serviços adjacentes e investidores em projectos
- Intenção para prevenir ser um mero "cliente chave na mão" como noutros sectores
- Devido à falta substancial de financiamento para primeiros dispositivos *full-scale* (5-15M€/MW), a 'eficiência de custos' para instalações futuras será decisiva. Maior factor de custo: operações marítimas e incerteza relacionada na fase inicial
- Investidores e tecnólogos iriam beneficiar de infra-estruturas, de testes 'abertas'

## Estudo de Mercado sobre Infraestruturas de *Energia Offshore*

→ WavEC, com apoio da GH, foi contratado para elaborar estudo, focando em:

- (1) Proposta para infraestruturas a serem geridas pelo *Instituto de Energia Offshore* a criar
- (2) Estimativa realista de custos de investimento e operacionais para 3-5 anos
- (3) Relação custo-benefício, em particular proposta em como financiar infraestruturas
- (4) Liaison com actores de mercado relevantes a nível internacional, para avaliar prontidão em contribuir para a implementação e funcionamento das infra-estruturas  
(← suportado por levantamento extenso no mercado com inquéritos)

As infraestruturas propostas, necessitando *feedback* de potenciais utentes

- (1) **Infra-estrutura de teste *Full-scale*** : área na costa oeste, totalmente exposta ao clima das ondas Atlântico, desenhado para testes de média a longa duração em escala real.
- (2) **Infra-estrutura de teste escala 1:4 : local** sítio ao largo de Faro, em clima de ondas semi-protegido, correspondendo à escala 1:4. Não ligado à rede; sobrevivência prioridade
- (3) **Pico OWC (CAO)**: central CAO existente com capacidade pneumática bastante elevada (~700kW), metade da estrutura ainda por usar; a ser desenvolvido para *test bed*.

# Considered test infrastructures

Apresentação acompanhando o inquérito – 8/12



Infrastructure exists, but would have to be rented



**Full-scale Aguçadora**  
(potential site) - EDP / EFACEC

Follow-up deployment sites adjacent



**Full-scale test site**  
(potential site) - Pilot zone / REN

Exists; has support team; need repairs



**OWC Pico plant**  
(WavEC)

Strong local support & co-financing; close to pilot zone



**Full-scale test site**  
(potential site) - Peniche

Lower average resource, higher accessibility



**Full-scale test site**  
(potential site) - Sines

Local support; moderate costs



**1:4 Scale test site**

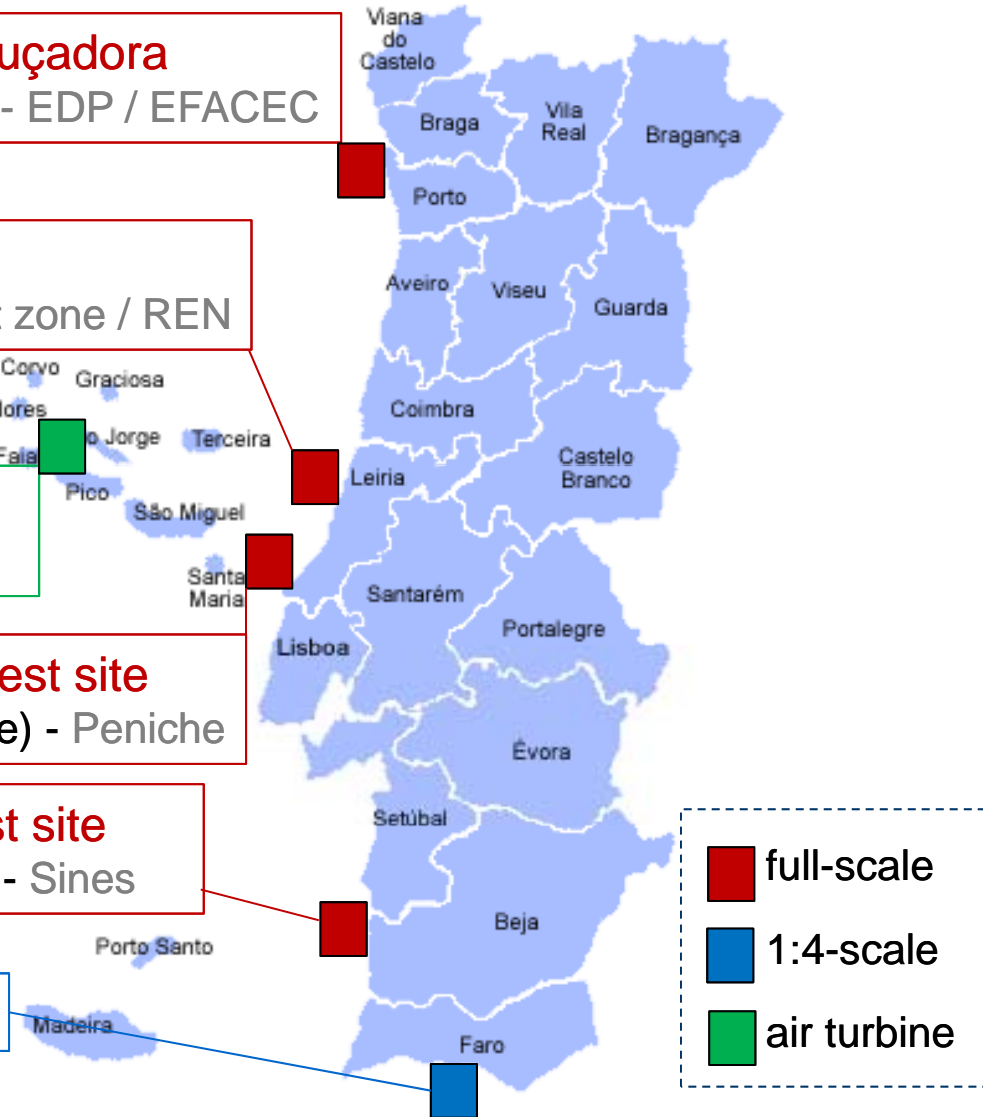

# Resultado dos inquéritos 1/3



- **Nível (qualidade e quantidade) das respostas dentro do esperado**
- **95 inquéritos enviados, 31 respostas 'completas' (23 tecnólogos, 5 investidores, mais 4 entidades Portugueses). Total de 35% dos inquéritos devolvidos**
- **'Full-scale' test site 3-5 MW considerado investimento mais interessante**
- **Geralmente houve preferência para os locais no Norte – Sines menos popular**
- **Níveis de renda propostos aparentemente realistas, no entanto maioria das respostas de tecnólogos em estado de desenvolvimento 'antes' do protótipo**
- **Maior concentração de candidatas esperados entre 2012 e 2013**

# Resultado dos inquéritos 2/3

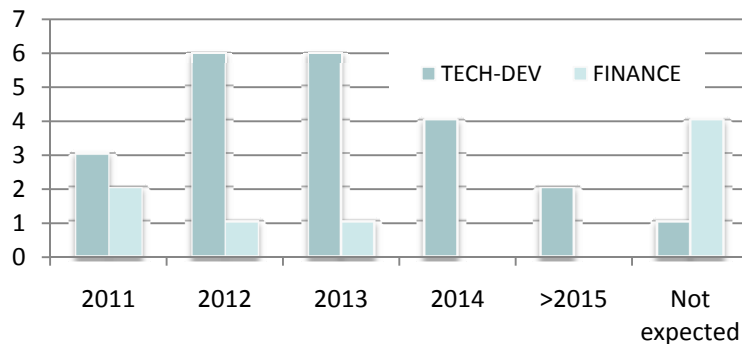
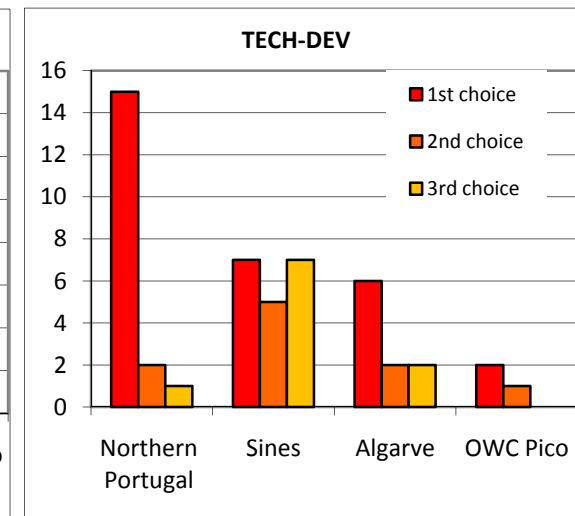
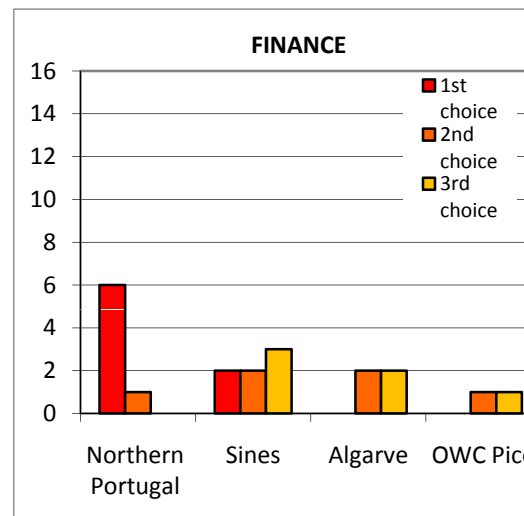
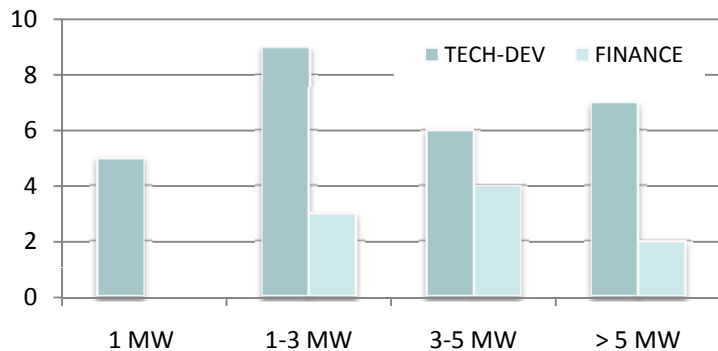
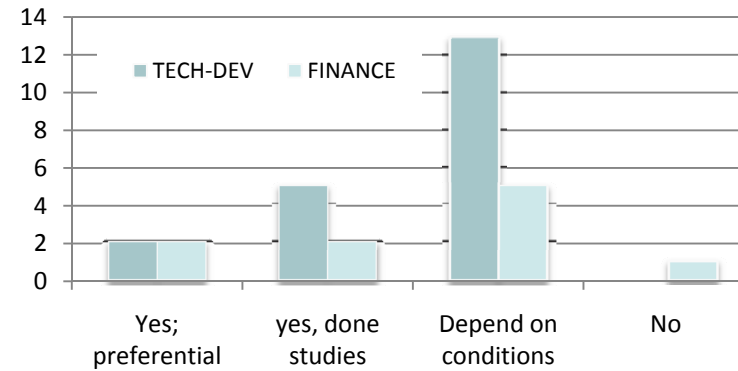
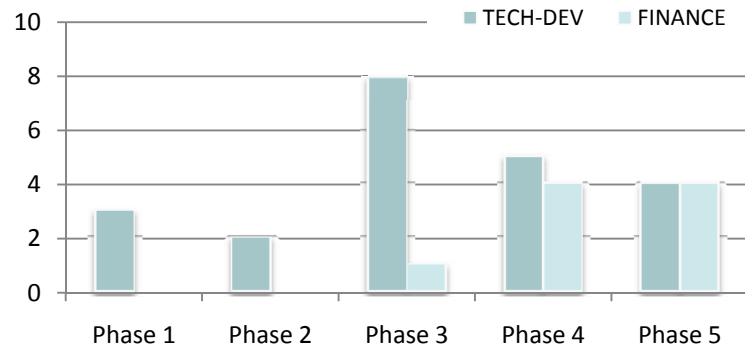

# Resultado dos inquéritos 3/3

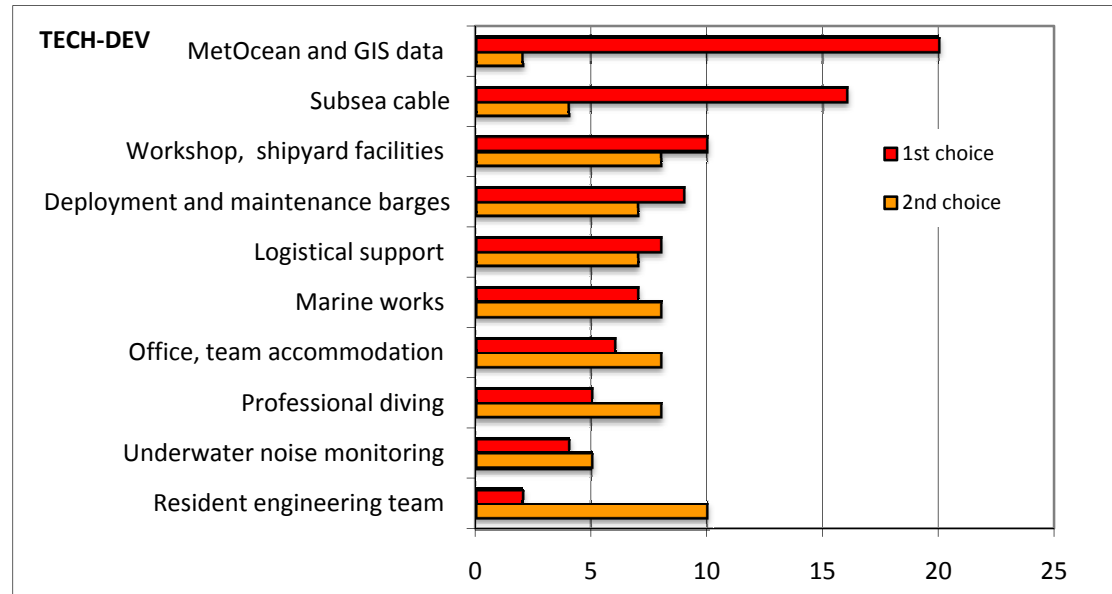
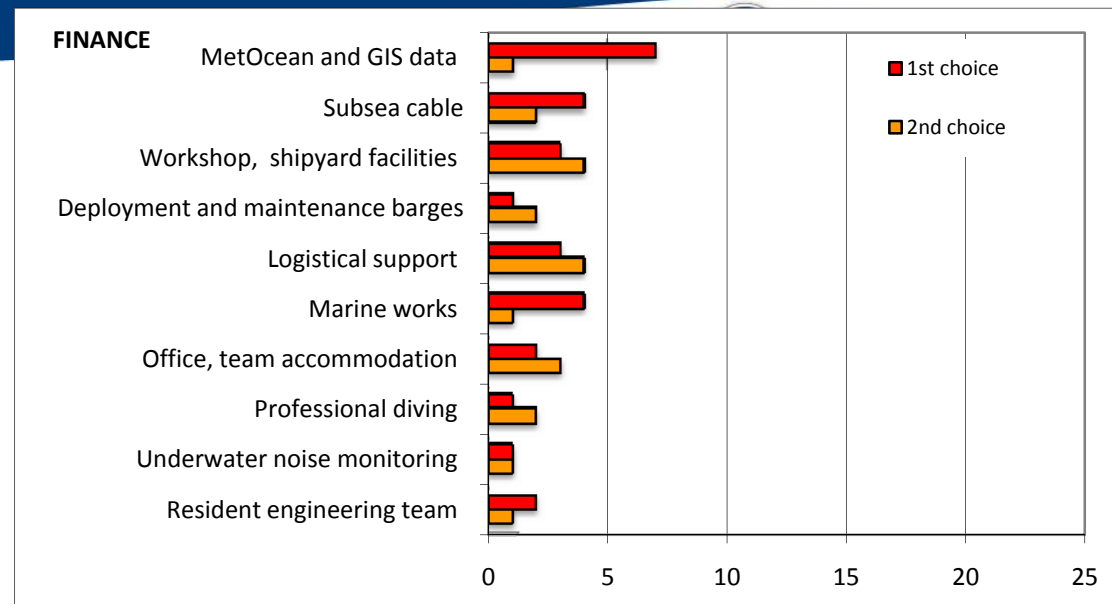
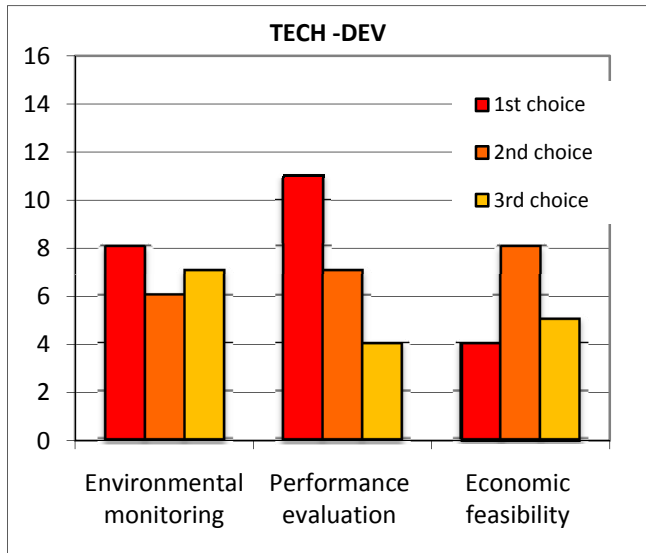
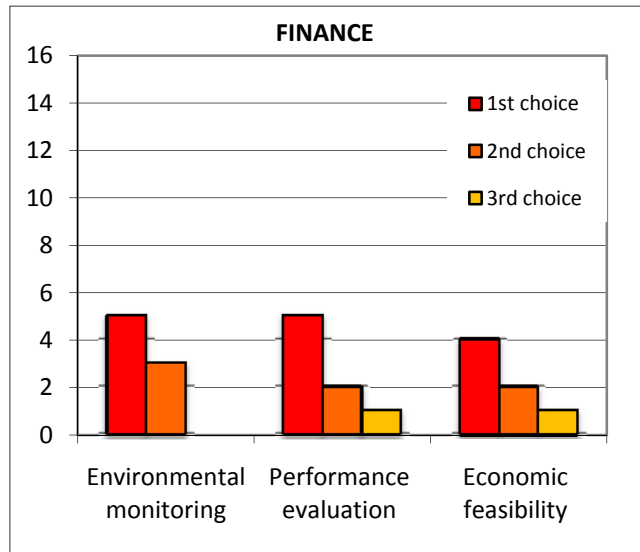

# Estimativa dos custos e base dos dados 1/3

- **Desafio principal: encontrar cenário de referência realista e não demasiado limitador.**
- **2 cabos separados com 2 MW cada, em 60 m profundidade. Adequado para a grande maioria de dispositivos, e corresponde resultados de inquérito**
- **Ligação à terra poderia ser feito com conector/ *splitter* offshore, no entanto cálculos indicativos mostraram custos e riscos mais elevados para casos**
- **Cabos dinâmicos e amarrações a ser fornecidos peos 'clientes'**

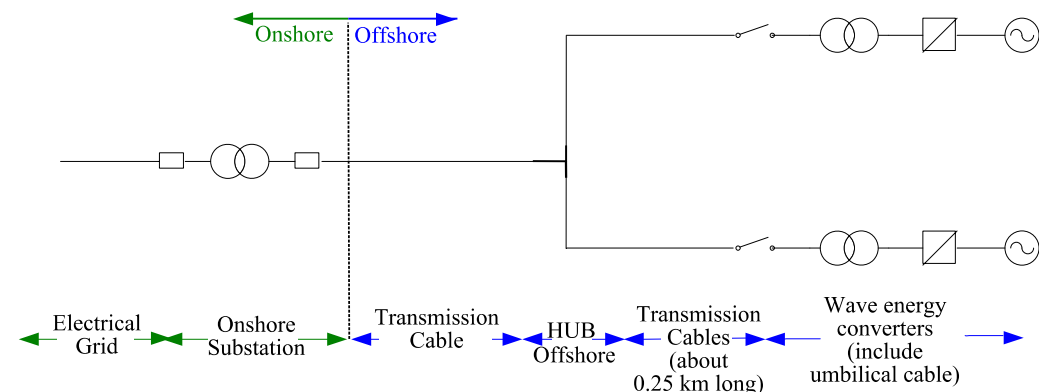
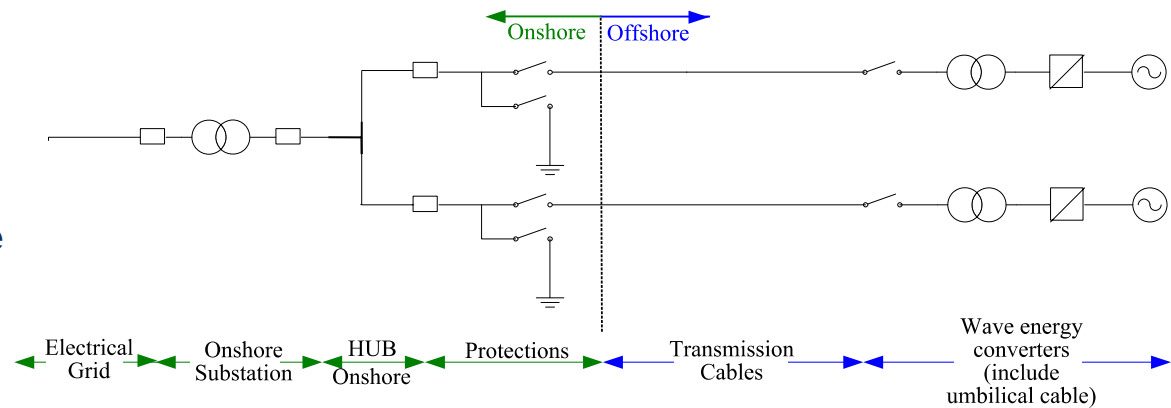

# Estimativa dos custos e base dos dados 2/3



- Base de dados compreensiva com 48 itens e 38 fontes de informação (referenciada e de comunicação pessoal)
- Nível de confiança razoável nos valores estimados (para este estado)

**CAPEX** Total EPC costs and contingency based on commercial data and reliable source from the offshore industry

**Costs in K€**

**DETAILED LISTING PER ITEM**

Id	Project Phase	Item	Subitem	Unit Rate (k€)	Unit	Sines	Sines	Penic	Zona	Aguç	Sines	Sines	Penic	Zona	Aguçad.	Total Cost A1	Total Cost A2	Total Cost B	Total Cost C	Total Cost D	Description
						1	2	he	Pilotoad.	1	2	he	Piloto								
1	Project Management	Project Management	Project Management	3% CAPEX		1	1	1	1	1	144	151	172	193	206						SWRDA[1] estimates 130k€ for Wave Hub development phase and 375k€ for construction phase (2,6% of budgeted). DTI [2] states 3% of CAPEX for typical offshore wind farms.
2	Consenting Phase	Surveys	Marine Sea Bed Surveys	91 km2		1.4	2.95	4.15	5.25	5.95	108	156	185	209	222						20MW but long cable distance (>50% mob/demob vessels). It is assumed (and it can be confirmed using both IH budgets) that the cost grows approximately as the square root of the area. Thus it is assumed 91k€/km as starting point and increasing with the area: 1km2 + the cable area (0,5km*cable length)
3	Consenting Phase	Surveys	Environmental Survey	100 project		1	1	1	1	1	100	100	100	100	100						Pilot zone report [4] report indicates a budget 79k€ for sea birds and cetacean characterization and 50k€ for "bentos" characterization from commercial offers from IPIMAR and IMAR. SWRDA estimates for Wave Hub [1] 360k€ surveys + 90k€ EIA. DTI [2] 225k€ for ES and 475k€ for EIA. GH [3] 1500k€ for EIA. [2] states that they estimate to increase/reduce with the sqr root of the size. EIA is probably not necessary for test site". IH [4] estimates 93,8k€ for meteo and oceanographic characterization based on historical data (13,7k€ for each of wave, tidal, meteo, currents + 39k€ for wave modelling). SWRDA [1] estimates 45k€ for wave hub wave, tidal, cetacean and surf impact assessments. Could be done by WavEC.
4	Consenting Phase	Surveys	Wind & Wave Climate	70 project		1	1	1	1	1	70	70	70	70	70						75k€ estimated by SWRDA of Wave Hub. Reduced using the square root of the size as advised by DTI.
7	Consenting Phase	Engineering fees	Preliminar Design development	34 project		1	1	1	1	1	34	34	34	34	34						75k€ estimated by SWRDA of Wave Hub. Reduced using the square root of the size as advised by DTI.
8	Consenting Phase	Consultancy	Consultancy during consenting phase	0.5% CAPEX		1	1	1	1	1	24	25	29	32	34						SWRDA [1] includes for Wave Hub around 350k€ which represents 1,7% of the projected budget. I assume 0,5% in the consenting phase and 1,2% in the post-consenting phase

# Estimativa dos custos e base dos dados 3/3



## ➤ Centro de Teste em escala estimado com base nos dados de 'full-scale'

Development Costs	Project Management	56	8% Assumed 3% of CAPEX
Development Costs	Consenting Costs	163	Surveys (marine bed, environmental, wind & wave climate), engineering fees, consulting, consenting and permitting costs, environmental assessment, navigation safety assessment, lease from authorities.
Development Costs	Post-Consenting Costs	50	Insurance, legal and financial costs, engineering fees, consultancy, procurement and contract, construction supervision, other costs
Construction	Subsea Cables	0	0% Procurement of 2MVA subsea cable (different km per specific location)
Construction	Subsea Connectors	0	0% Procurement of subsea hub and connectors
Construction	Offshore Installation	0	0% Installation of subsea cable and connectors, mob&demob vessels, weather downtime
Construction	Onshore Electrical Equipment	0	0% Procurement and installation of offshore-onshore cable beach connection, substation (with transformer, switchgear, protections) and cable to grid connection.
Construction	Navigation & Met-Ocean Buoys	216	30% Procurement and installation of marker buoys (one including RACON) and met-ocean buoy.
Construction	Support Services Infrastructure	235	Office & equipment, semi-rigid vessel, land vehicle, control system & SCADA, monitoring and communication equipment and miscellaneous.
		<b>721</b>	

## ➤ Centro de Teste de turbinas no Pico estimado com base de dados históricos

1	Development Costs	Project Management	50	Assumed 5% of CAPEX
2 to 12	Development Costs	Engineering Design	60	Assistance in planning and design of basic rehabilitation measures of concrete structure; second turbine duct preparation; test bed and auxiliaries; benchmarks for electrical and mechanical parts of modular test bed
13 to 18	Development Costs	Post-Consenting Costs	60	Insurance, legal and financial costs, other engineering fees, consultancy, procurement and contract, construction supervision, other costs (partly subcontracted, estimated duration 12 months)
19+20	Construction	Concrete structure rehabilitation	500	Constructive measures for plant rehabilitation (especially designed protective formworks (~8m high) 100k€; seabed and joint insulation and high capacity pumping 100k€; subsea horizontal constructive drilling 200k€; subsea reinforced concrete 200m3 --> 100k€ (assumed unit cost of 500€/m3 including all secondary costs)
21+22	Construction	Modular Test bed structural	150	Breakthrough and mounting of second exterior bellmouth 20 k€; recovery of existing isolation valve 20 k€; plant floor preparation and foundation 10k€; modular structural support 30k€; ducts and adaption pieces 20k€; additional fast-acting valve 50k€
23 to 28	Construction	Modular Test bed electronics	400	Additional grid connection point in plant or substitution of existing power electronics with modern, adjustable system for rated power levels of ~ 100-500 kW
29 to 34	Construction	Accessibility and safety improvement	50	Procurement and installation of offshore-onshore cable beach connection, substation (with transformer, switchgear, protections) and cable to grid connection.
35 to 37	Construction	Met-Ocean and plant measurements	65	Procurement and installation of met-ocean measurement device and auxiliaries.
38 to 46	Construction	Support Services Infrastructure	170	Office & equipment, transformer containers, land vehicle, control system & SCADA, monitoring and communication equipment and miscellaneous.
<b>Total</b>			<b>1505</b>	

# Modelo económico



Project Assumptions		Financial Assumptions	
Number of Berths	2	Capita wg	75,0%
Capacity per Berth	2	l grant kg	0%
Avg. Months per Project	6	Privat e we	12,5%
Berth Rent fee*	55	Equity ke	12%
Test Centre Lifetime	15	Bank wd	12,5%
Delay between proj.	1	Debt kd	5%
Avg. Berth Occ.**	50%	Debt duration	15
CAPEX		Inflation	1,5%
OPEX			

Base OPEX	Annual Cost (k€/year)	% CAPEX
Permanent Staff	60	0,9%
Office Overheads	10	0,1%
Insurance	100	1,4%
Planned Maintenance	60	0,9%
Unplanned Maintenance	30	0,4%
Spare/Refit	12	0,2%
Environmental Monitoring	16	0,2%
Others	30	0,4%
Total	318	

	Rental Fee		Avg. Berth Occupation		Test Centre Life		Base OPEX		CAPEX Total		Capital Grant	
	Input	NPV	Input	NPV	Input	NPV	Input	NPV	Input	NPV	Input	NPV
<b>Ref</b>	<b>55</b>	<b>1167</b>	<b>50%</b>	<b>1167</b>	<b>15</b>	<b>1167</b>	<b>Variation</b>	<b>1167</b>	<b>Variation</b>	<b>1167</b>	<b>75%</b>	<b>1167</b>
Input Variation	80	2506	100%	4643	20	1448	200%	-2786	100%	359	75%	1189
	70	1988	80%	3271	16	1252	100%	-670	50%	789	60%	732
	60	1458	60%	1896	12	963	50%	314	25%	997	50%	419
	40	338	40%	442	8	537	25%	764	-25%	1367	25%	-380
	30	-266	20%	-1266	5	105	-25%	1601	-50%	1528	10%	-869
	20	-951	10%	-2170	3	-240	-50%	2007	-100%	1843	0%	-1203

Exemplo:  
Sines1 (A1)

# 'Ranking' das infra-estruturas 'full-scale'



- **Sugestão: Ranking apenas com base de custos esperados para cada local. Decisão final será mais regional / 'político' e depende do financiamento público**

Rank	Site	IRR Shareholders	NPV Shareholders [k€]	CAPEX [k€]	Private Funding [k€]
1	Sines1	44%	1167	4865	1216
2	Sines2	40%	1116	5140	1285
3	Peniche	35%	1004	5817	1454
4	Zona Piloto	30%	885	6505	1626
5	Aguçadoura	28%	811	6923	1731

Site	IRR Shareholders	NPV Shareholders [k€]	CAPEX [k€]	Private Funding [k€]
Algarve	34%	123	721	180
Pico OWC	4%	-61	1505	372

- **Em todos os casos, 50-75% financiamento público será essencial para realização**